

IGBT - Field Stop, Trench, Soft Fast Recovery Diode

1700V/450A

Features

- Electrical features
 - $V_{CES}=1700V$
 - $I_{C\ nom}=450A / I_{CRM}=900A$
 - Low switching losses
 - Low inductance
 - Fast switching and short tail current
 - Integrated NTC temperature sensor
 - High power and thermal cycling capability
- Mechanical features
 - Integrated NTC temperature sensor
 - High power and thermal cycling capability
 - Al_2O_3 substrate with low thermal resistance
 - Copper base plate
- Potential Applications
 - Switching mode power supply
 - Drive inverters with brake system
 - Uninterruptible power supply
 - AC and DC servo drive amplifier



Device	Package	Shipping
SPM450V170D3HS	ED3	Tray

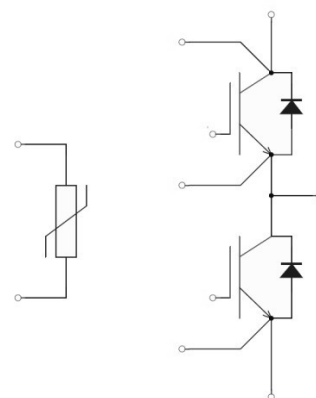

IGBT, Inverter

Maximum Rated Values

Parameter	Note or test condition	Symbol	Values	Unit
Collector-emitter voltage	$T_{vj} = 25^{\circ}\text{C}$	V_{CES}	1700	V
Continuous DC collector current	$T_C = 100^{\circ}\text{C}, T_{vj, \max} = 150^{\circ}\text{C}$	$I_{C \text{ nom}}$	450	A
Repetitive peak collector current	$t_P = 1 \text{ ms}$	I_{CRM}	900	A
Total power dissipation	$T_C = 25^{\circ}\text{C}, T_{vj, \max} = 175^{\circ}\text{C}$	P_{tot}	1600	W
Gate-emitter peak voltage		V_{GES}	+/- 20	V

Characteristic value

Parameter	Note or test condition	Symbol	Values			Unit	
			Min.	Typ.	Max.		
Collector-emitter saturation voltage	$I_C = 450 \text{ A}, V_{GE} = 15 \text{ V}$	$V_{CE, \text{sat}}$	$T_{vj} = 25^{\circ}\text{C}$	1.45	1.65	1.85	V
			$T_{vj} = 125^{\circ}\text{C}$		2.00		V
			$T_{vj} = 150^{\circ}\text{C}$		2.08		V
Gate threshold voltage	$I_C = 3 \text{ mA}, V_{CE} = V_{GE}, T_{vj} = 25^{\circ}\text{C}$	$V_{GE, \text{th}}$	5.0	5.6	6.2	V	
Gate charge	$V_{GE} = -15 \text{ V} \dots +15 \text{ V}$	Q_G		5.2		μC	
Internal gate resistor	$T_{vj} = 25^{\circ}\text{C}$	R_{Gint}		1.2		Ω	
Input capacitance	$f=1\text{MHz}, T_{vj}=25^{\circ}\text{C}, V_{CE}=25\text{V}, V_{GE}=0\text{V}$	C_{ies}		72		nF	
Reverse transfer capacitance	$f=1\text{MHz}, T_{vj}=25^{\circ}\text{C}, V_{CE}=25\text{V}, V_{GE}=0\text{V}$	C_{res}		0.6		nF	
Collector-emitter cut-off current	$V_{CE} = 1700 \text{ V}, V_{GE} = 0 \text{ V}, T_{vj} = 25^{\circ}\text{C}$	I_{CES}			3	mA	
Gate-emitter leakage current	$V_{CE} = 0 \text{ V}, V_{GE} = 20 \text{ V}, T_{vj} = 25^{\circ}\text{C}$	I_{GES}			300	nA	
Turn-on delay time, inductive load	$I_C = 450\text{A}, V_{CE} = 900\text{V}$	$T_{vj} = 25^{\circ}\text{C}$	$t_{d, \text{on}}$		0.26	us	
	$V_{GE} = +15/-15\text{V}$	$T_{vj} = 125^{\circ}\text{C}$			0.29		us
	$R_{G, \text{on}} = 3.3\Omega$	$T_{vj} = 150^{\circ}\text{C}$			0.29		us
Rise time, inductive load	$I_C = 450\text{A}, V_{CE} = 900\text{V}$	$T_{vj} = 25^{\circ}\text{C}$	t_r		0.10	us	
	$V_{GE} = +15/-15\text{V}$	$T_{vj} = 125^{\circ}\text{C}$			0.12		us
	$R_{G, \text{on}} = 3.3\Omega$	$T_{vj} = 150^{\circ}\text{C}$			0.13		us

(table continues...)

Parameter	Note or test condition		Symbol	Values			Unit
				Min.	Typ.	Max.	
Turn-off delay time, inductive load	$I_C = 450A, V_{CE} = 900V$	$T_{vj} = 25^\circ C$	$t_{d,off}$		0.62		us
	$V_{GE} = +15/-15V$	$T_{vj} = 125^\circ C$			0.70		us
	$R_{G,off} = 3.3\Omega$	$T_{vj} = 150^\circ C$			0.73		us
Fall time, inductive load	$I_C = 450A, V_{CE} = 900V$	$T_{vj} = 25^\circ C$	t_f		0.20		us
	$V_{GE} = +15/-15V$	$T_{vj} = 125^\circ C$			0.27		us
	$R_{G,off} = 3.3\Omega$	$T_{vj} = 150^\circ C$			0.21		us
Turn-on energy loss per pulse	$I_C = 450A, V_{CE} = 900V, L_s = 35nH$	$T_{vj} = 25^\circ C$	E_{on}		78.5		mJ
	$V_{GE} = +15/-15V, di/dt = 2770A/\mu s$	$T_{vj} = 125^\circ C$			116.6		mJ
	$R_{G,on} = 3.3\Omega (T_{vj} = 150^\circ C)$	$T_{vj} = 150^\circ C$			125.5		mJ
Turn-off energy loss per pulse	$I_C = 450A, V_{CE} = 900V, L_s = 35nH$	$T_{vj} = 25^\circ C$	E_{off}		84.6		mJ
	$V_{GE} = +15/-15V, dv/dt = 3900V/\mu s$	$T_{vj} = 125^\circ C$			121.5		mJ
	$R_{G,off} = 3.3\Omega (T_{vj} = 150^\circ C)$	$T_{vj} = 150^\circ C$			137.6		mJ
SC data	$V_{GE} \leq 15V, V_{CC} = 900V, t_p \leq 8\mu s, T_{vj} = 150^\circ C, C_{GE} = 0.0\mu F, V_{CEmax} = V_{CES} - L_{sCE} \cdot di/dt$		I_{sc}		2400		A
Thermal resistance, junction to case	Per IGBT		$R_{th,Jc}$			0.078	K/W

Diode, Inverter

Maximum Rated Values

Parameter	Note or test condition	Symbol	Values	Unit
Repetitive peak reverse voltage	$T_{vj} = 25^\circ C$	V_{RRM}	1700	V
Continuous DC forward current		I_F	450	A
Repetitive peak forward current	$t_p = 1ms$	I_{FRM}	900	A

Characteristic value

Parameter	Note or test condition	Symbol	Values			Unit	
			Min.	Typ.	Max.		
Forward voltage	$I_F = 450\text{ A}, V_{GE} = 0\text{ V}$	V_F		1.88		V	
				2.05		V	
				2.10		V	
Peak reverse recovery current	$I_F = 450\text{ A}, V_R = 900\text{ V}$	I_{RM}		558		A	
	$V_{GE} = -15\text{ V}, -di_F/dt = 2000\text{ A}/\mu\text{s}$			$T_{vj} = 125^\circ\text{C}$		500	A
	$(T_{vj}=150^\circ\text{C})$			$T_{vj} = 150^\circ\text{C}$		500	A
Recovered charge	$I_F = 450\text{ A}, V_R = 900\text{ V}$	Q_r		121.5		μC	
	$V_{GE} = -15\text{ V}, -di_F/dt = 2000\text{ A}/\mu\text{s}$			$T_{vj} = 125^\circ\text{C}$		160.0	μC
	$(T_{vj}=150^\circ\text{C})$			$T_{vj} = 150^\circ\text{C}$		176.1	μC
Reverse recovery energy	$I_F = 450\text{ A}, V_R = 900\text{ V}$	E_{rec}		69.6		mJ	
	$V_{GE} = -15\text{ V}, -di_F/dt = 2000\text{ A}/\mu\text{s}$			$T_{vj} = 125^\circ\text{C}$		93.4	mJ
	$(T_{vj}=150^\circ\text{C})$			$T_{vj} = 150^\circ\text{C}$		103.6	mJ
Thermal resistance, junction to case	Per diode	$R_{th,JC}$			0.152	K/W	

NTC-Thermistor

Characteristic value

Parameter	Note or test condition	Symbol	Values			Unit
			Min.	Typ.	Max.	
Rated resistance	$T_C = 25^\circ\text{C}$	R_{25}		5.00		K Ω
Power dissipation	$T_C = 25^\circ\text{C}$	P_{25}			20	mW
B-value B-Z	$R_2 = R_{25} \exp[B_{25/50}(1/T_2 - 1/(298, 15K))]$	B_{25}/B_{50}		3375		K
B-value B-Z	$R_2 = R_{25} \exp[B_{25/75}(1/T_2 - 1/(298, 15K))]$	B_{25}/B_{75}		3408		K
B-value B-Z	$R_2 = R_{25} \exp[B_{25/100}(1/T_2 - 1/(298, 15K))]$	B_{25}/B_{100}		3436		K

Module

Characteristic value

Parameter	Note or test condition	Symbol	Values			Unit
			Min.	Typ.	Max.	
Isolation Voltage	RMS, f=50HZ,1min	V_{ISOL}			3400	V
Stray inductance module		L_{SCE}		35		nH
Operation Junction Temperature		T_{Jop}	-40		150	°C
Storage Temperature Range		T_{stg}	-40		125	°C
Mounting Torque	Screw M5	M	3		6	N.m
Weight of Module		G		350		g

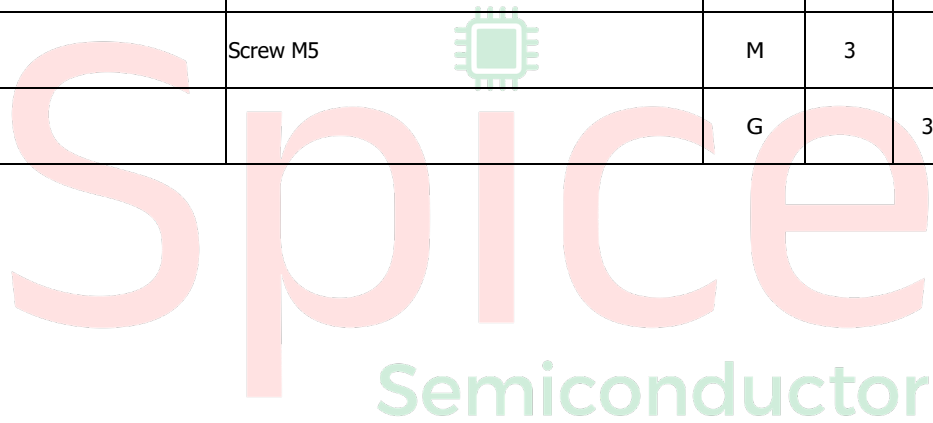

Characteristics diagrams

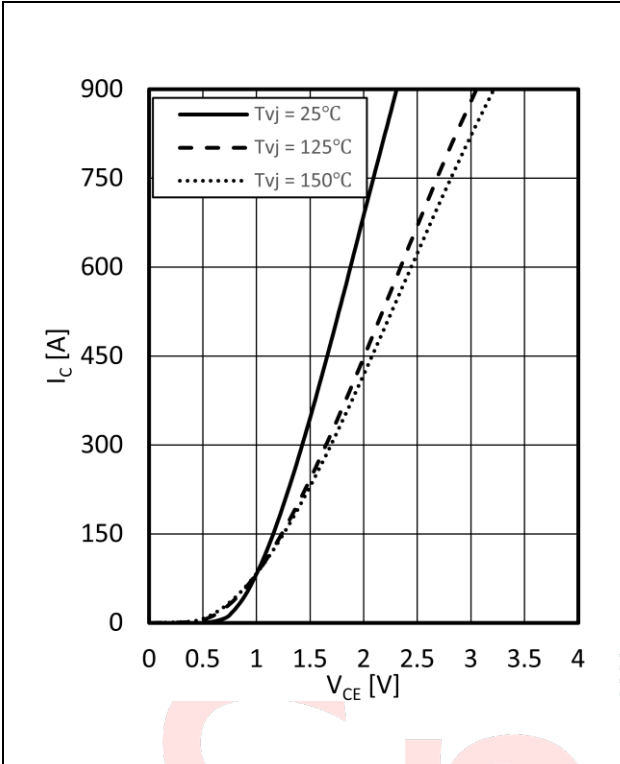

Output characteristic IGBT, Inverter (typical)
 $I_C = f(V_{CE})$ $V_{GE} = 15\text{V}$

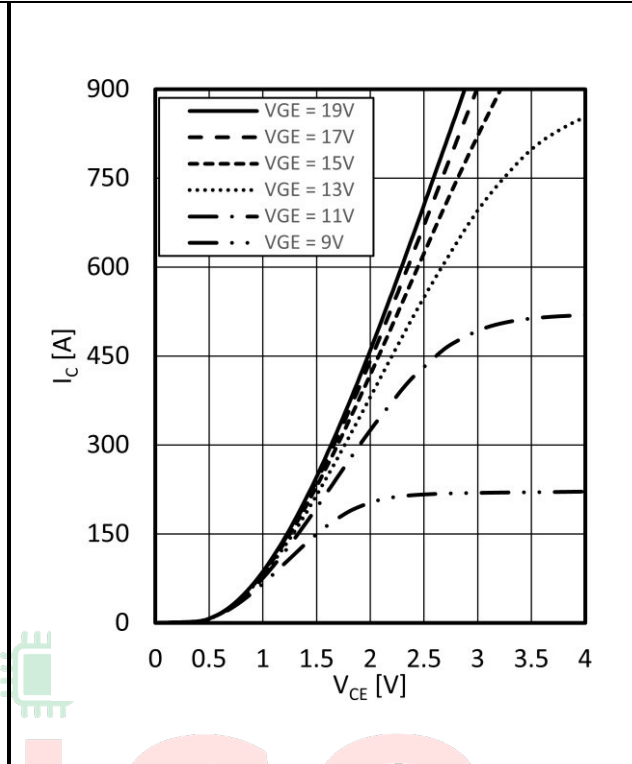

Output characteristic IGBT, Inverter (typical)
 $I_C = f(V_{CE})$ $T_{vj} = 150^\circ\text{C}$

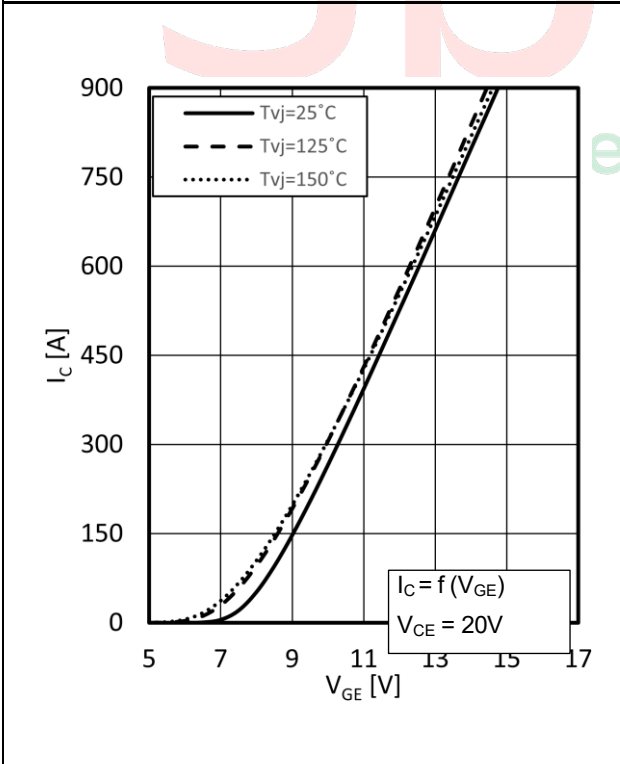

Transfer characteristic IGBT, Inverter (typical)
 $I_C = f(V_{GE})$ $V_{CE} = 20\text{V}$

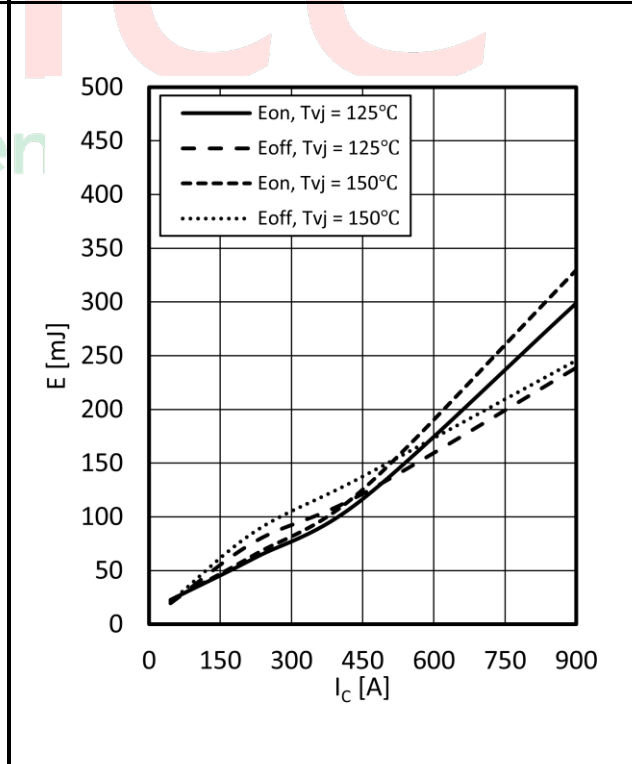

Switching losses IGBT, Inverter (typical)
 $E_{on} = f(I_C)$, $E_{off} = f(I_C)$ $V_{GE} = \pm 15\text{V}$, $R_{Gon} = 3.3 \Omega$ $R_{Goff} = 3.3 \Omega$, $V_{CE} = 900\text{V}$

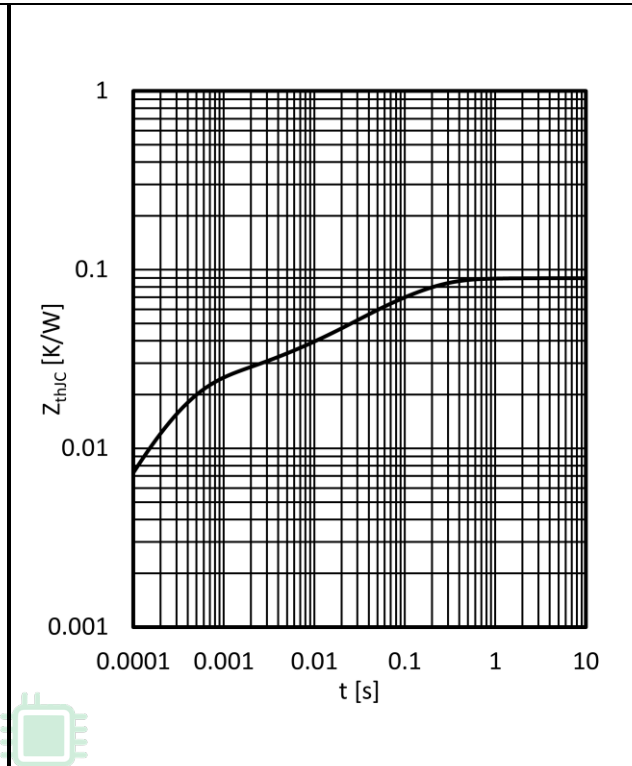
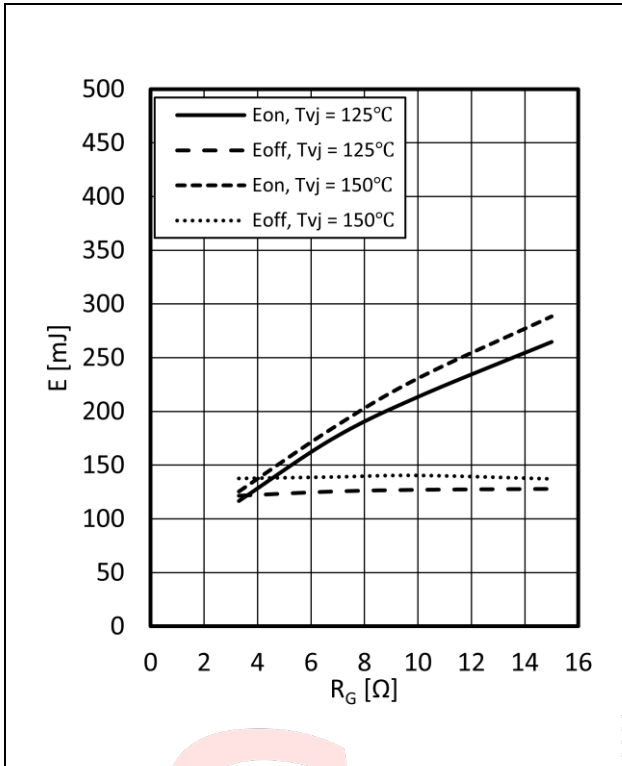

Switching losses IGBT, Inverter (typical)
 $E_{on} = f(R_G)$, $E_{off} = f(R_G)$ $V_{GE} = \pm 15V$, $I_C = 450A$, $V_{CE} = 900V$

Transient thermal impedance IGBT, Inverter
 $Z_{thJC} = f(t)$

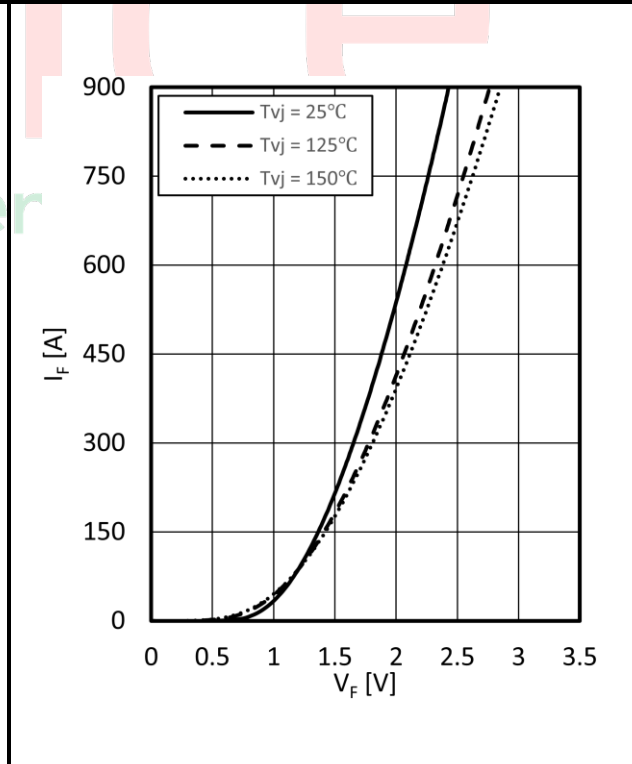
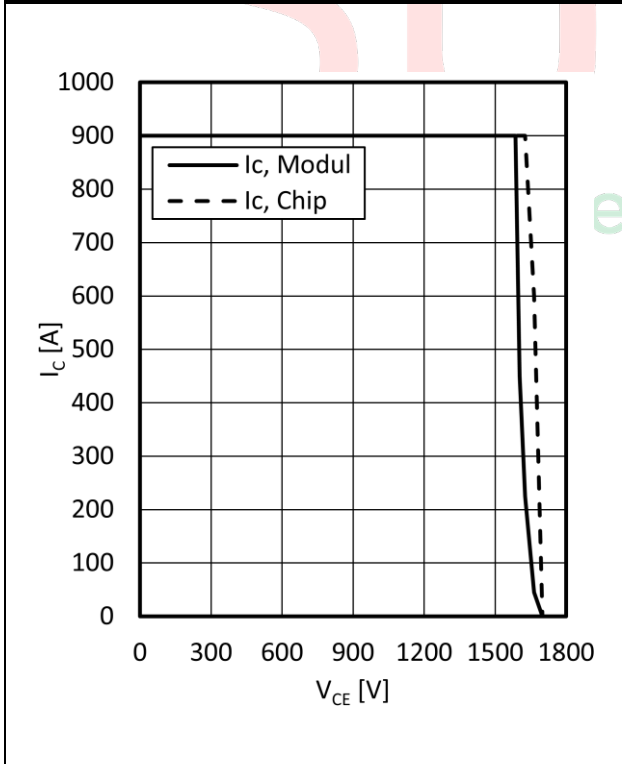

Reverse bias safe operating area IGBT, Inverter (RBSOA)
 $I_C = f(V_{CE})$ $V_{GE} = \pm 15V$ $R_{Goff} = 3.3\Omega$, $T_{vj} = 150^\circ C$

Forward characteristic of Diode, Inverter (typical)
 $I_F = f(V_F)$

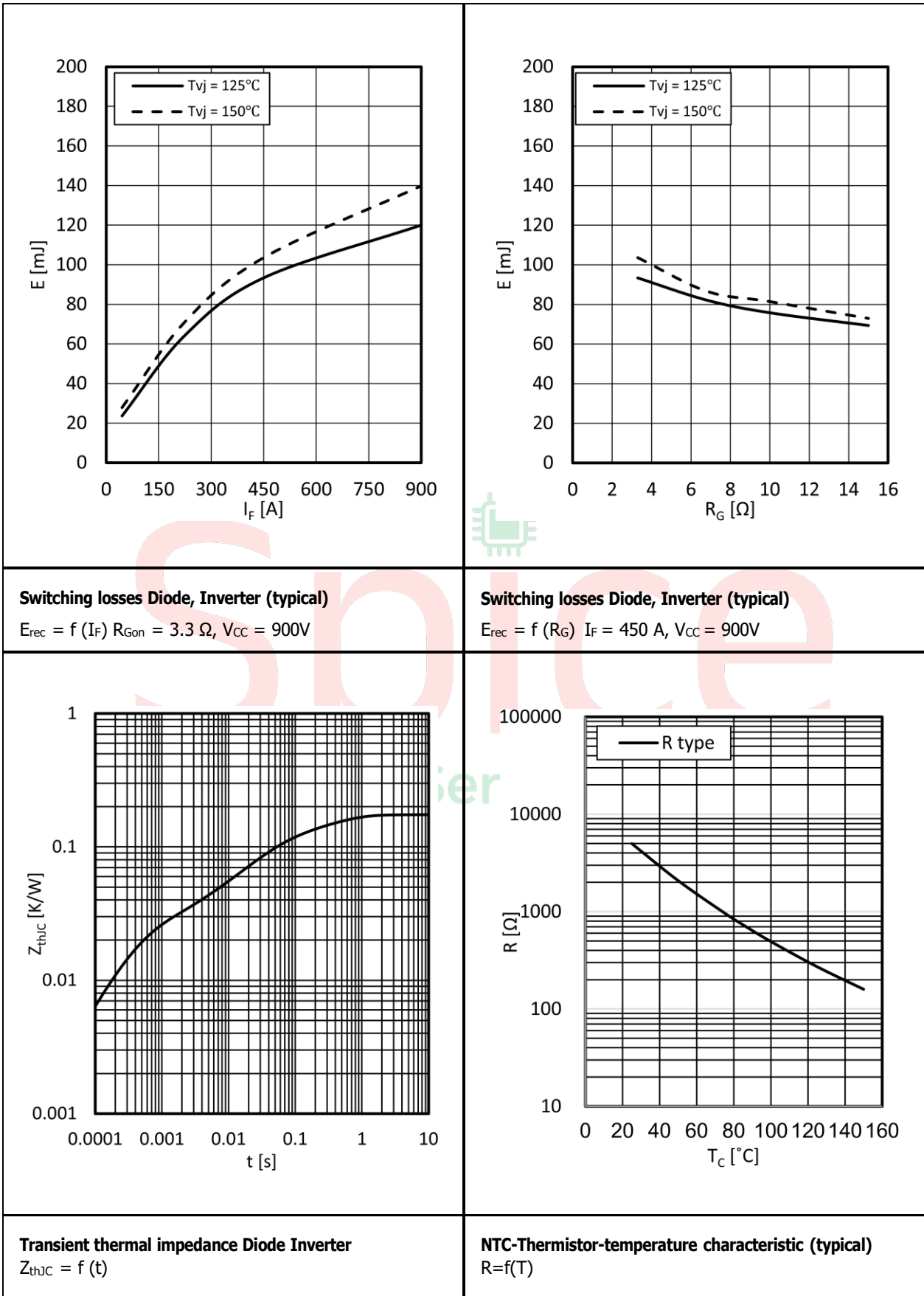

Circuit Diagram

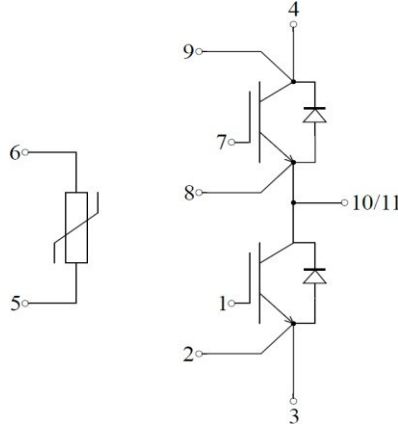

Package Outlines

