

## 1. Product Features

### 1.1 Electrical features

- $V_{CES}=650V$
- $I_{C\ nom}=100A / I_{CRM}=200A$
- Low switching losses
- Low inductance
- Fast switching and short tail current
- High power and thermal cycling capability

### 1.2 Mechanical features

- $Al_2O_3$  substrate with low thermal resistance
- Copper base plate



Figure1 IGBT Module

## 2. Typical Applications

- Switching mode power supply
- Uninterruptible power supply

## 3. Description

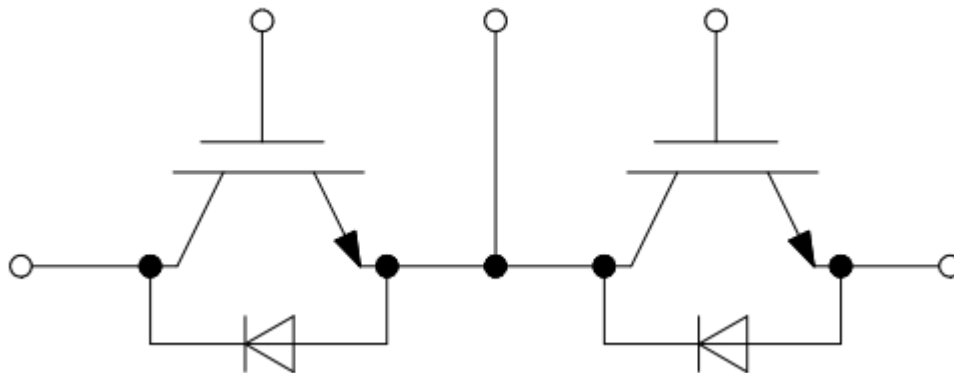

Figure 2 Half Bridge

## 4. IGBT

### 4.1 Maximum rated values

Parameter	Note or test condition	Symbol	Values	Unit
Collector-emitter voltage	$T_{vj} = 25^{\circ}C$	$V_{CES}$	650	V
Continuous DC collector current	$T_C = 75^{\circ}C, T_{vj\ max} = 150^{\circ}C$	$I_{C\ nom}$	100	A
Repetitive peak collector current	$t_p = 1\ ms$	$I_{CRM}$	200	A
Total power dissipation	$T_C = 25^{\circ}C, T_{vj\ max} = 175^{\circ}C$	$P_{tot}$	440	W
Gate-emitter peak voltage		$V_{GES}$	+/- 20	V

## 4.2 Characteristic value

Parameter	Note or test condition	Symbol	Values			Unit
			Min.	Typ.	Max.	
Collector-emitter saturation voltage	$I_C = 100\text{ A}$ , $V_{GE} = 15\text{ V}$	$T_{vj} = 25^\circ\text{C}$	$V_{CE,sat}$		1.37	V
		$T_{vj} = 125^\circ\text{C}$			1.47	V
		$T_{vj} = 150^\circ\text{C}$			1.51	V
Gate threshold voltage	$I_C = 1.5\text{ mA}$ , $V_{CE} = V_{GE}$ , $T_{vj} = 25^\circ\text{C}$	$V_{GE,th}$	5.0	5.7	6.5	V
Gate charge	$V_{GE} = -15\text{ V} \dots +15\text{ V}$	$Q_G$		0.48		$\mu\text{C}$
Internal gate resistor	$T_{vj} = 25^\circ\text{C}$	$R_{Gint}$		2.60		*
Input capacitance	$f=1\text{ MHz}$ , $T_{vj}=25^\circ\text{C}$ , $V_{CE}=25\text{V}$ , $V_{GE}=0\text{V}$	$C_{ies}$		0.89		nF
Reverse transfer capacitance	$f=1\text{ MHz}$ , $T_{vj}=25^\circ\text{C}$ , $V_{CE}=25\text{V}$ , $V_{GE}=0\text{V}$	$C_{res}$		0.08		nF
Collector-emitter cut-off current	$V_{CE} = 650\text{ V}$ , $V_{GE} = 0\text{ V}$ , $T_{vj} = 25^\circ\text{C}$	$I_{CES}$		0.5		mA
Gate-emitter leakage current	$V_{CE} = 0\text{ V}$ , $V_{GE} = 20\text{ V}$ , $T_{vj} = 25^\circ\text{C}$	$I_{GES}$			100	nA
Turn-on delay time, inductive load	$I_C = 100\text{ A}$ , $V_{CE} = 300\text{V}$ $V_{GE} = +15/-15\text{V}$ $R_{G,on} = 1\Omega$	$T_{vj} = 25^\circ\text{C}$	$t_{d,on}$		0.05	us
		$T_{vj} = 125^\circ\text{C}$			0.06	us
		$T_{vj} = 150^\circ\text{C}$			0.06	us
Rise time, inductive load	$I_C = 100\text{ A}$ , $V_{CE} = 300\text{V}$ $V_{GE} = +15/-15\text{V}$ $R_{G,on} = 1\Omega$	$T_{vj} = 25^\circ\text{C}$	$t_r$		0.03	us
		$T_{vj} = 125^\circ\text{C}$			0.03	us
		$T_{vj} = 150^\circ\text{C}$			0.04	us

(table continues...)

Parameter	Note or test condition	Symbol	Values			Unit
			Min.	Typ.	Max.	
Turn-off delay time, inductive load	$I_C = 100\text{ A}$ , $V_{CE} = 300\text{V}$ $V_{GE} = +15/-15\text{V}$ $R_{G,on} = 1\Omega$	$T_{vj} = 25^\circ\text{C}$	$t_{d,off}$		0.13	us
		$T_{vj} = 125^\circ\text{C}$			0.16	us
		$T_{vj} = 150^\circ\text{C}$			0.17	us
Fall time, inductive load	$I_C = 100\text{ A}$ , $V_{CE} = 300\text{V}$ $V_{GE} = +15/-15\text{V}$ $R_{G,on} = 1\Omega$	$T_{vj} = 25^\circ\text{C}$	$t_f$		0.13	us
		$T_{vj} = 125^\circ\text{C}$			0.18	us
		$T_{vj} = 150^\circ\text{C}$			0.19	us
Turn-on energy loss per pulse	$I_C = 100\text{ A}$ , $V_{CE} = 300\text{V}$ , $L_s=60\text{nH}$ $V_{GE} = +15/-15\text{V}$ , $di/dt = 3389\text{ A}/\mu\text{s}$ $R_{G,on} = 1\Omega$ ( $T_{vj} = 150^\circ\text{C}$ )	$T_{vj} = 25^\circ\text{C}$	$E_{on}$		0.10	mJ
		$T_{vj} = 125^\circ\text{C}$			0.32	mJ
		$T_{vj} = 150^\circ\text{C}$			0.40	mJ
Turn-off energy loss per pulse	$I_C = 100\text{ A}$ , $V_{CE} = 300\text{V}$ , $L_s=60\text{nH}$ $V_{GE} = +15/-15\text{V}$ , $dv/dt = 3906\text{ V}/\mu\text{s}$ $R_{G,off} = 1\Omega$ ( $T_{vj} = 150^\circ\text{C}$ )	$T_{vj} = 25^\circ\text{C}$	$E_{off}$		4.77	mJ
		$T_{vj} = 125^\circ\text{C}$			6.18	mJ
		$T_{vj} = 150^\circ\text{C}$			6.49	mJ

SC data	$V_{GE} \leq 15V$ , $V_{CC} = 300V$ , $t_P \leq 6 \mu s$ , $T_{vj} = 150^\circ C$ , $C_{GE} = 0.0\mu F$ , $V_{CEmax} = V_{CES} - L_{sGE} \cdot di/dt$	$I_{SC}$		1836		
Thermal resistance, junction to case	Per IGBT	$R_{th,jc}$			0.34	K/W

## 5. Diode

### 5.1 Maximum rated values

Parameter	Note or test condition	Symbol	Values	Unit
Repetitive peak reverse voltage	$T_{vj} = 25^\circ C$	$V_{RBM}$	650	V
Continuous DC forward current		$I_F$	100	A
Repetitive peak forward current	$t_P = 1 ms$	$I_{FRM}$	200	A

### 5.2 Characteristic value

Parameter	Note or test condition	Symbol	Values			Unit
			Min.	Typ.	Max.	
Forward voltage	$I_F = 100 A$ , $V_{GE} = 0 V$	$V_F$		1.63		V
				1.38		V
				1.32		V

(table continues...)

Parameter	Note or test condition	Symbol	Values			Unit
			Min.	Typ.	Max.	
Peak reverse recovery current	$I_F = 100A$ , $V_R = 300V$	$I_{RM}$		38.3		A
	$V_{GE} = -15V$ , $- di_F/dt = 1139 A/\mu s$			110.8		A
	( $T_{vj}=150^\circ C$ )			125.0		A
Recovered charge	$I_F = 100A$ , $V_R = 300V$	$Q_r$		7.76		$\mu C$
	$V_{GE} = -15V$ , $- di_F/dt = 1139 A/\mu s$			10.1		$\mu C$
	( $T_{vj}=150^\circ C$ )			11.7		$\mu C$
Reverse recovery energy	$I_F = 100A$ , $V_R = 300V$	$E_{rec}$		2.31		mJ
	$V_{GE} = -15V$ , $- di_F/dt = 1139 A/\mu s$			2.89		mJ
	( $T_{vj}=150^\circ C$ )			3.34		mJ
Thermal resistance, junction to case	Per diode	$R_{th,jc}$			0.64	K/W

## 6. Module

### 6.1 Characteristic value

Parameter	Note or test condition	Symbol	Values			Unit
			Min.	Typ.	Max.	
Isolation Voltage	RMS, f=50HZ, 1min	V <sub>ISOL</sub>			4000	V
Stray inductance module		L <sub>CE</sub>		30		nH
Operation Junction Temperature		T <sub>JP</sub>	-40		150	°C
Storage Temperature Range		T <sub>stg</sub>	-40		125	°C
Mounting Torque	Screw M6	M	3.0		5.0	N.m
Terminal Connection Torque	Screw M5	M	2.5		5.0	N.m
Weight of Module		G		160		g



**7. Characteristics diagrams**

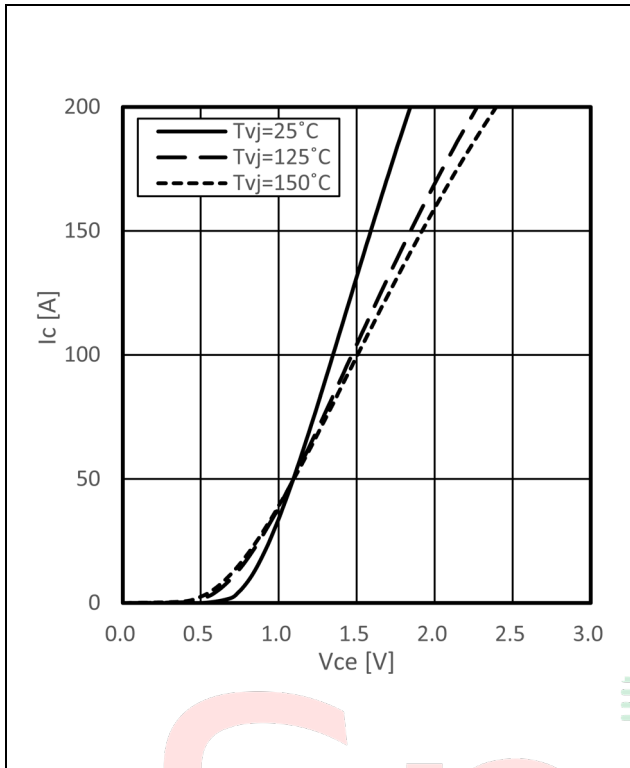

**Output characteristic IGBT (typical)**

$I_c = f(V_{ce})$   
 $V_{GE} = 15V$

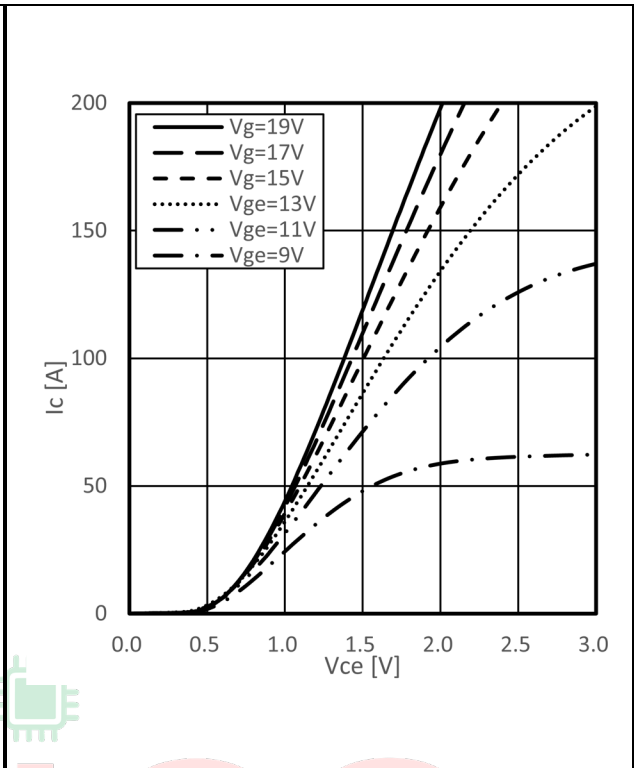

**Output characteristic IGBT (typical)**

$I_c = f(V_{ce})$   
 $T_{vj} = 150^\circ C$

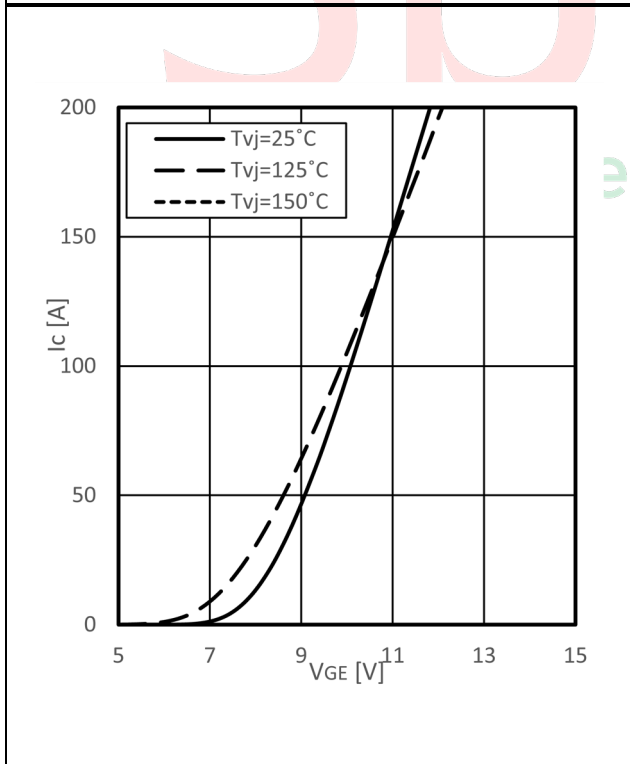

**Transfer characteristic IGBT (typical)**

$I_c = f(V_{GE})$   
 $V_{CE} = 20V$

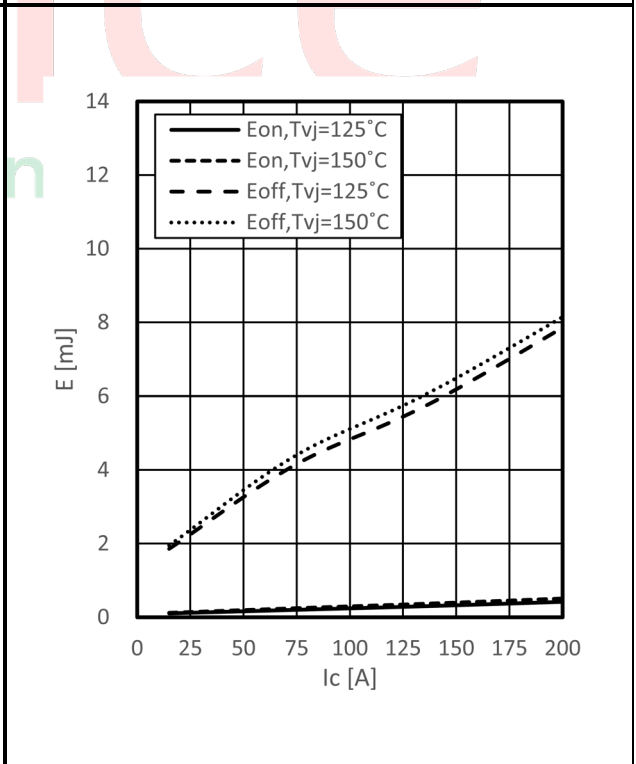

**Switching losses IGBT (typical)**

$E_{on} = f(I_c), E_{off} = f(I_c)$   
 $R_{Goff} = 1 \Omega, R_{Gon} = 1 \Omega, V_{CE} = 300 V, V_{GE} = \pm 15 V$

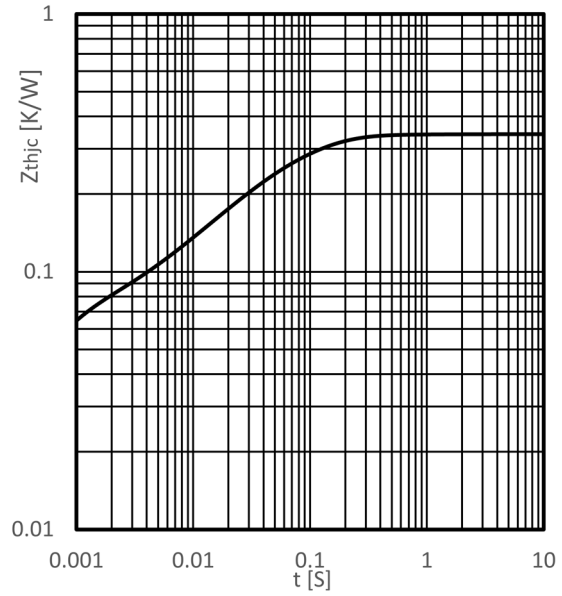
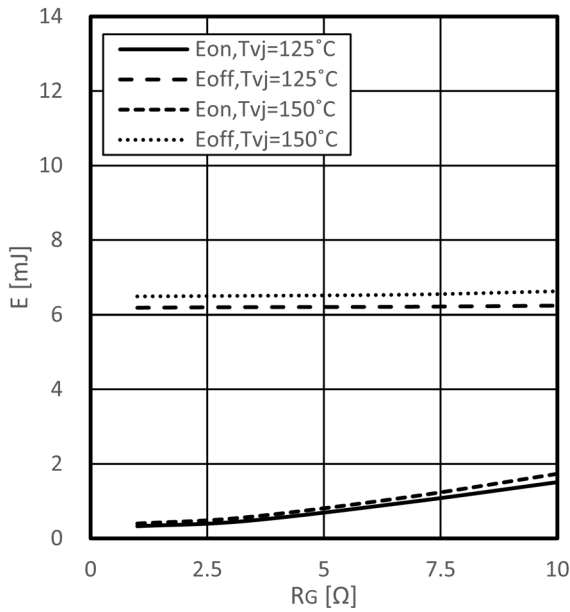

**Switching losses IGBT (typical)**

$E_{on} = f(R_G)$ ,  $E_{off} = f(R_G)$   
 $I_C = 100 \text{ A}$ ,  $V_{CE} = 300 \text{ V}$ ,  $V_{GE} = \pm 15 \text{ V}$

**Transient thermal impedance IGBT**

$Z_{thjc} = f(t)$

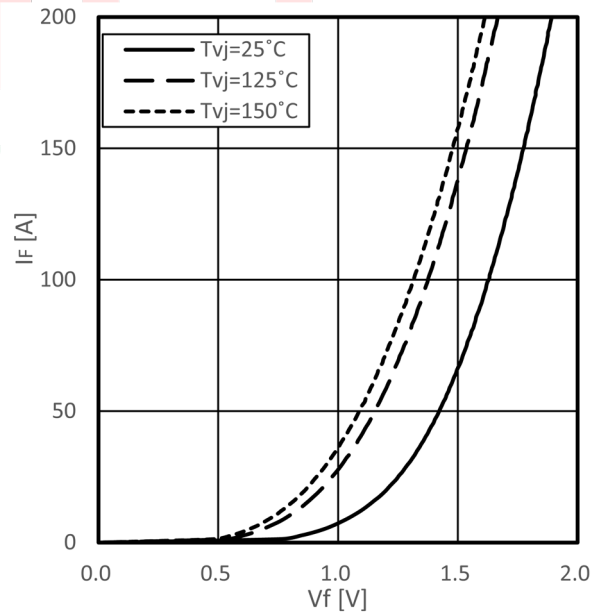
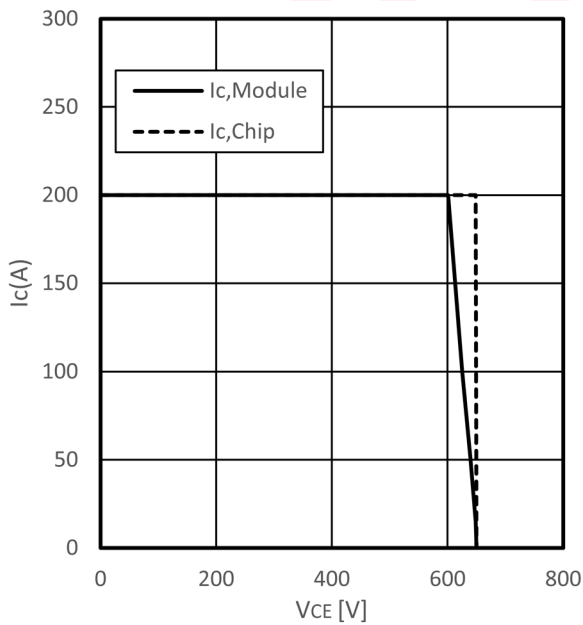

**Reverse bias safe operating area IGBT (RBSOA)**

$I_C = f(V_{CE})$   
 $V_{GE} = 15 \text{ V}$ ,  $R_{Goff} = 1\Omega$ ,  $T_{vj} = 150 \text{ }^\circ\text{C}$

**Forward characteristic of Diode, Inverter (typical)**

$I_F = f(V_F)$

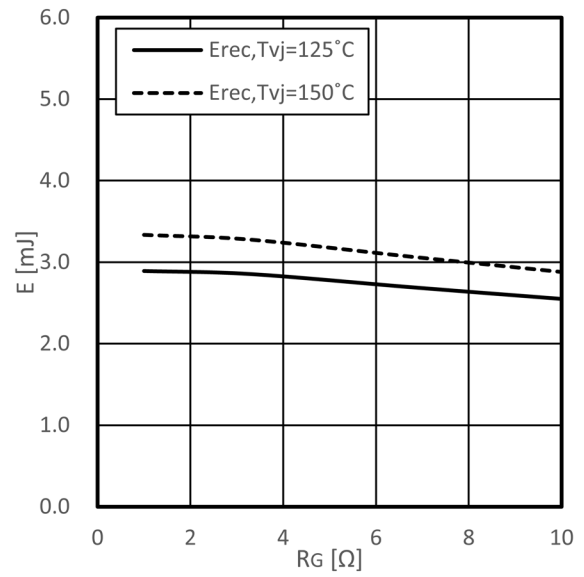
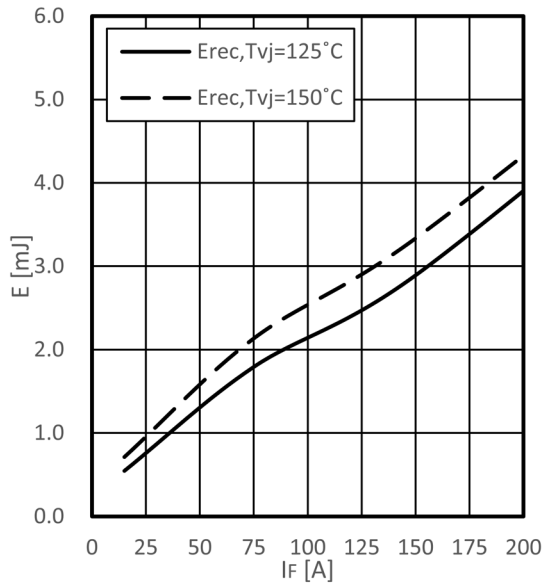

**Switching losses Diode (typical)**

$E_{rec} = f(I_F)$   
 $R_{gon} = 1 \Omega, V_{CE} = 300 \text{ V}$

**Switching losses Diode (typical)**

$E_{on} = f(R_g), E_{off} = f(R_g)$   
 $I_c = 100 \text{ A}, V_{CE} = 300 \text{ V}, V_{GE} = \pm 15 \text{ V}$

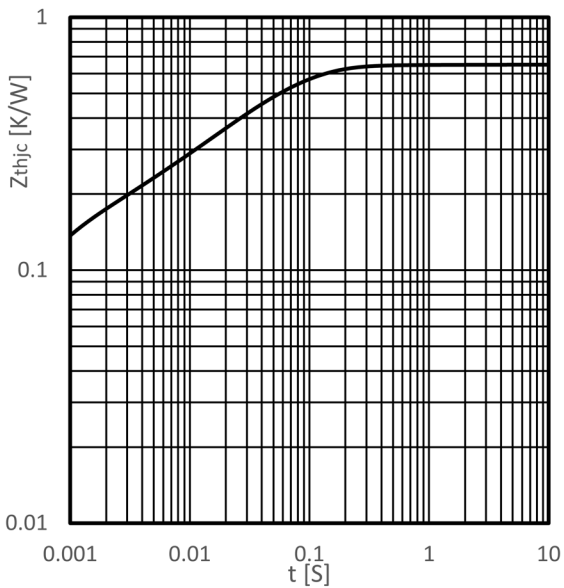

**Transient thermal impedance Diode**

$Z_{thjc} = f(t)$

**8. Circuit Diagram**

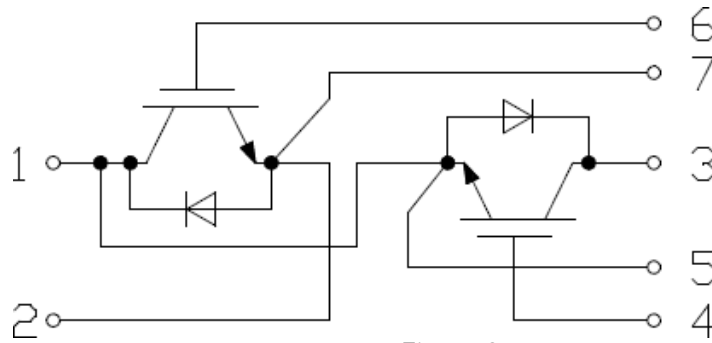

Figure 3

## 9. Package Outlines

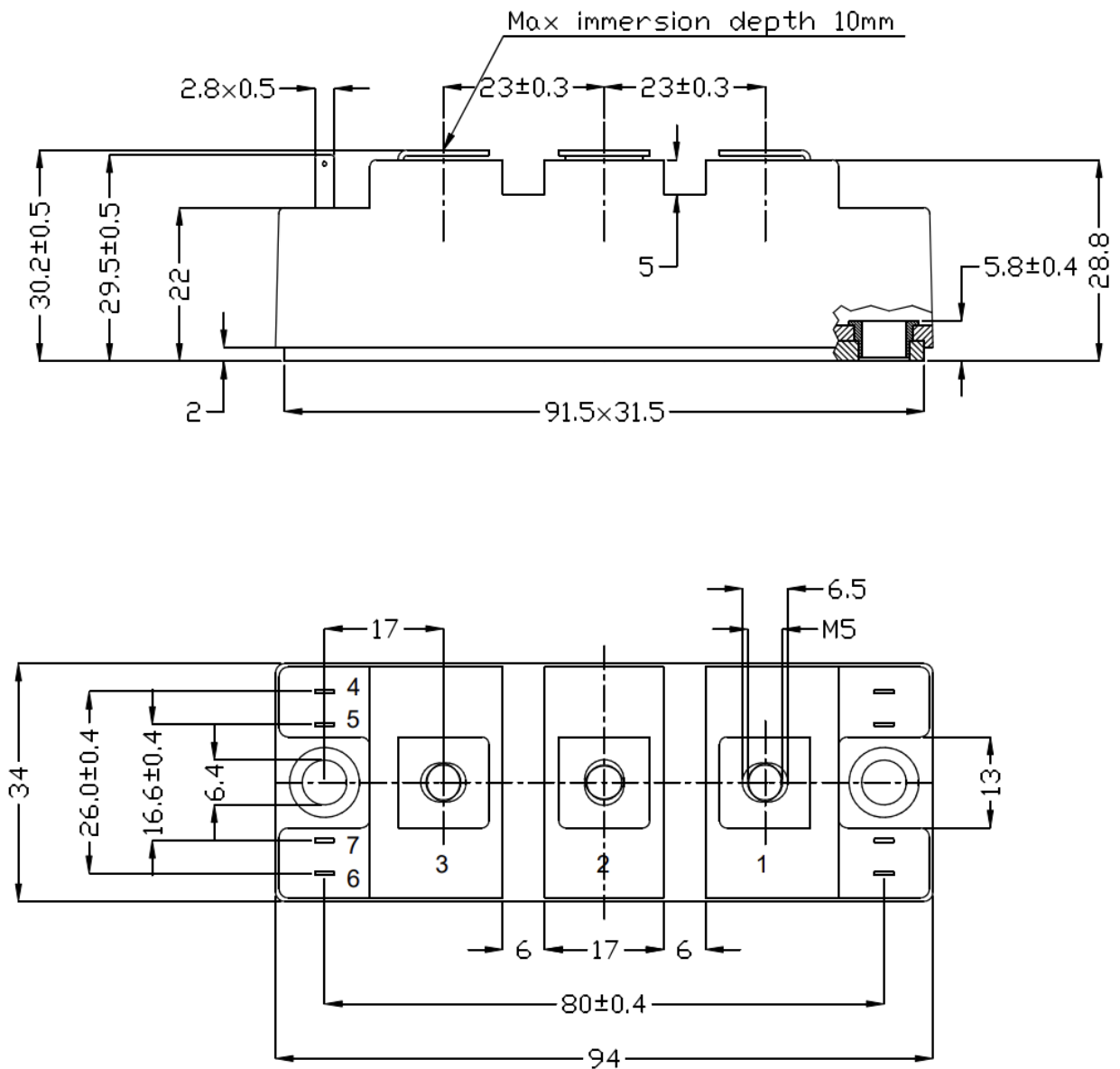

Figure 4